

# TA500 TOP ARM MEASURING MACHINE

## Heavy duty, multi-purpose measuring top arm which accepts materials over 3mm in diameter.

This is a heavy duty measuring top arm designed for the measurement of cable, wire, rope, hose, extrusions or any continuous materials from 3mm diameter.

Pivoting at one end, the arm hangs down onto the material being measured.

The pivot arm TA500 uses a ½ metre precision ground measuring wheel which can be either knurled aluminium or polyurethane covered.

- All aluminium / stainless steel construction (does not include mechanical counter).
- Can be fitted with an electronic NPN encoder if required.
- Available in four different travel directions A, B, C or D. See diagram showing direction of material and view from front of counter.

### Specifications:

- Cable diameter range 3mm and greater.
- 6 Digit mechanical counter reading 99999.9 metres.
- Measuring wheel circumference 500mm
- Maximum speed of travel 1500 Metres per min
- Measurement in Metres and Centimetres.
- Fixings: One hole diameter 14mm.
- Gross weight 3.5 Kg

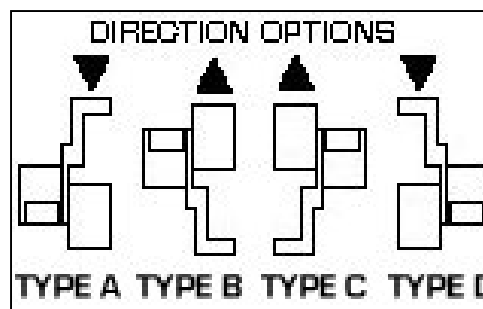
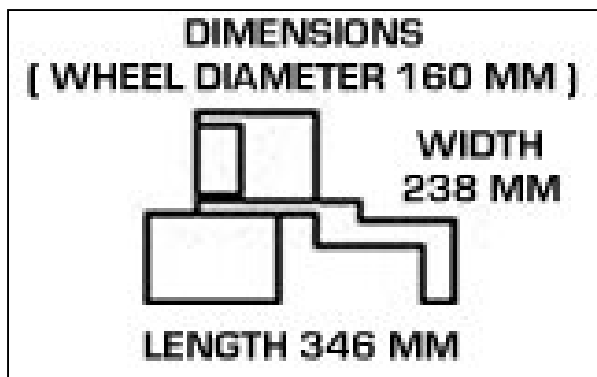
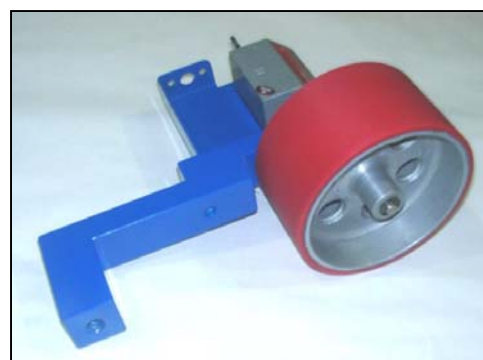
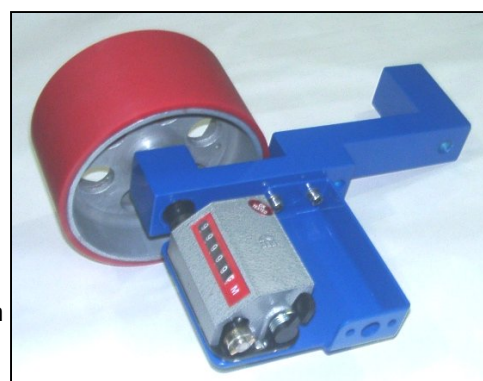
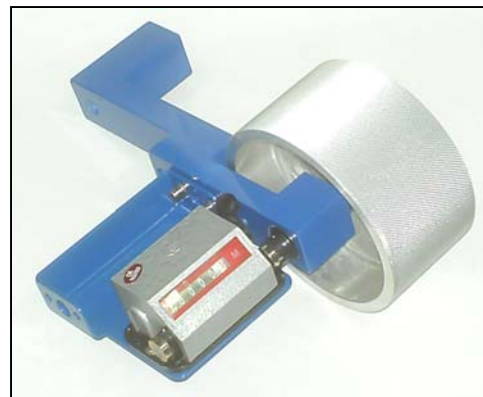

**NESSLEGROVE TECHNOLOGIES LTD Tel: #44 (0) 1453 886440**

[www.nesslegrove.com](http://www.nesslegrove.com)

E-mail: [nesstech@btconnect.com](mailto:nesstech@btconnect.com)